

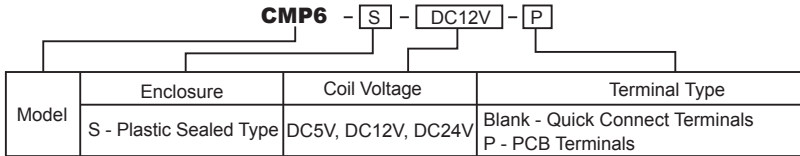

Features	
■	Miniature relay with high switching contact capacity, 20A/250VAC
■	Dielectric strength of 4500V between coil and contacts
■	Ideal for switching compressor and inverter loads
■	Available in both PCB and quick connect terminals
■	Applications: Air conditioners, refrigerators, OA equipment, etc
Safety Approval	
US NO.E164730	NO.CQC08002027610
NO.50091133	NO.1369391(LR 109368)



ORDERING INFORMATION



Remark: 1. Available in 1 Form A only

SPECIFICATION

CONTACT DATA

Contact Form	1 Form A	
Contact Material	Ag Alloy	
Contact Rating	Resistive: 20A 250VAC/30VDC Inrush Current: 80A Break Current: 20A	
Contact Resistance	Max. 100mΩ(6VDC 1A)	
Load	Max. Switching Voltage	250VAC/30VDC
	Max. Switching Current	20A
	Max. Switching Power	5,000VA, 600W
	Min. Switching Load	5VDC, 100mA
Life	Electrical	100,000 operations
	Mechanical	20,000,000 operations

COIL DATA

Nominal Coil Power	900mW
--------------------	-------

GENERAL DATA

Insulation Resistance	Min. 1000MΩ 500VDC	
Dielectric Strength	Between open contacts	1,000VAC, 1min
	Between coil and contacts	4,500VAC, 1min
Operate Time	Max. 20ms	
Release Time	Max. 10ms	
Operating Temperature	-20°C to +55°C	
Humidity	35~95%RH, +40°C	
Shock Resistance	Endurance	1,000m/s ²
	Misoperation	100m/s ²
Vibration Resistance	Endurance	10~55Hz, 1.5mm double amplitude
	Misoperation	10~55Hz, 1.5mm double amplitude
Weight	Approximately 21.0g	

Note: Data shown are of initial value

SAFETY APPROVAL

File Number	Contact Form	Power Consumption	Coil Voltage	Contact Rating	Remarks
UL E164730	A	0.9W	5 - 24VDC	20A 250VAC	Ambient Temperature: 55°C
				12A 250VAC, 2HP	
	A	0.9W	5 - 24VDC	HP: 2HP 240VAC	Ambient Temperature: 55°C
				FLA/LRA: 20/80A, 120VAC	

ISO9001、ISO/TS16949、ISO14001 Approved

CMP6

POWER RELAY

SAFETY APPROVAL

File Number	Contact Form	Power Consumption	Coil Voltage	Contact Rating	Remarks
CSA 1369391 (LR 109368)	A	0.9W	5 - 24VDC	20A 250VAC	Ambient Temperature: 23°C
TUV 50091133	A	0.9W	5, 12, 24VDC	20A 250VAC, $\cos\Phi=0.9$ Inrush Current: 80A 250VAC, 0.3s, $\cos\Phi=0.7$	Ambient Temperature: 85°C
CQC08002027610 (GB/T 21711.1-2008)	A	0.9W	5 - 24VDC	20A 250VAC	Ambient Temperature: 85°C

Specifications subject to change without notice

COIL DATA

Ambient Temperature: 23°C

Model	Nominal Voltage VDC	Coil Resistance Ω +/-10%	Operate Voltage \leq VDC	Release Voltage \geq VDC	Coil Power mW
CMP6-S-DC5V	5	27.8	3.5	0.5	900
CMP6-S-DC12V	12	160	8.4	1.2	
CMP6-S-DC24V	24	640	16.8	2.4	

OUTLINE, WIRING DIAGRAM, MOUNTING HOLE LAYOUT (UNIT: mm)

Quick connect type

Outline

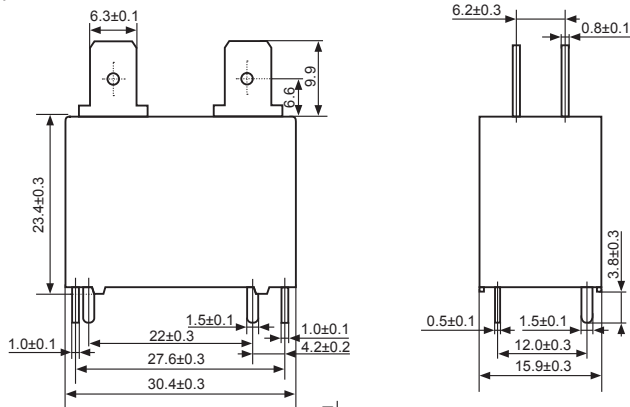

Mounting Hole Layout
(Bottom View)

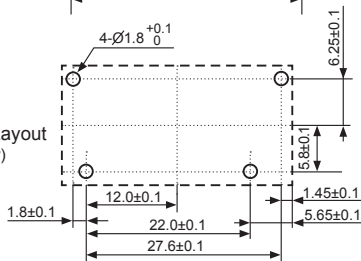

Wiring Diagram

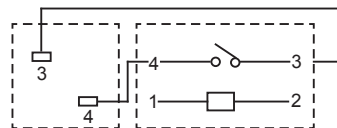

ISO9001、ISO/TS16949、ISO14001 Approved

HKE CMP6-125

CMP6

POWER RELAY

OUTLINE, WIRING DIAGRAM, MOUNTING HOLE LAYOUT (UNIT: mm)

PCB type

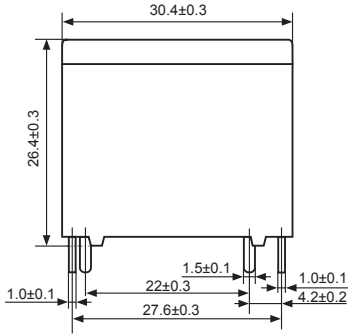

Outline

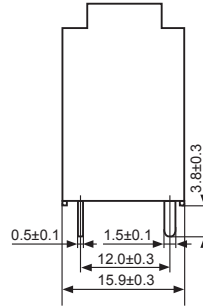

Wiring Diagram
(Bottom View)

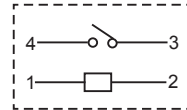

Mounting Hole Layout
(Bottom View)

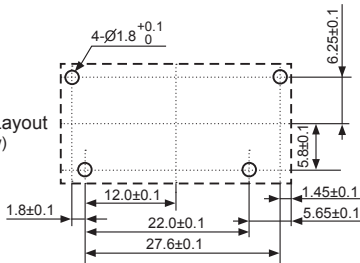

REFERENCE DATA

Maximum Switching Power

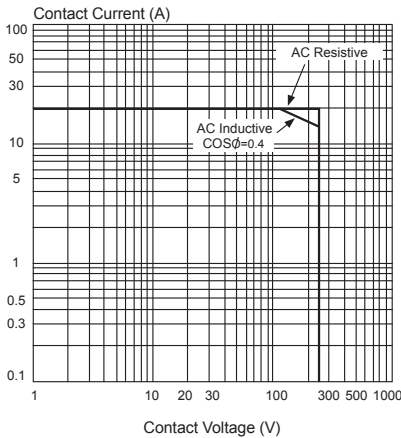

Life Curves

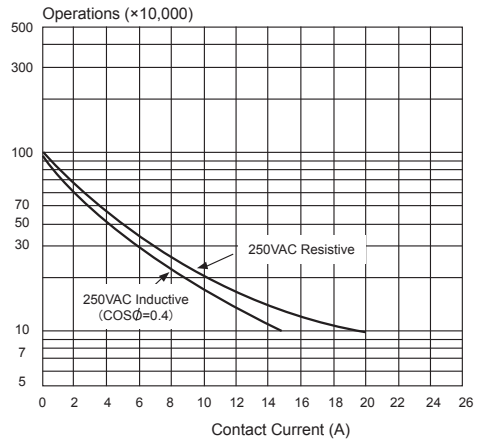

ISO9001、ISO/TS16949、ISO14001 Approved